

MODEL NO.	"L"	P/N
PBCT22TS	610 [24]	83280
PBCT28TS	244 [96]	65884
PBCT24TS	1219 [48]	48069
PBCT25TS	1524 [60]	48020
PBCT210TS	3048 [120]	48025
PBCT23TS	1000 [39]	42794

NOTE: "TS" SUFFIX DESIGNATES FIBER TO BE USED WITH DI2 "FP" SERIES SENSORS.

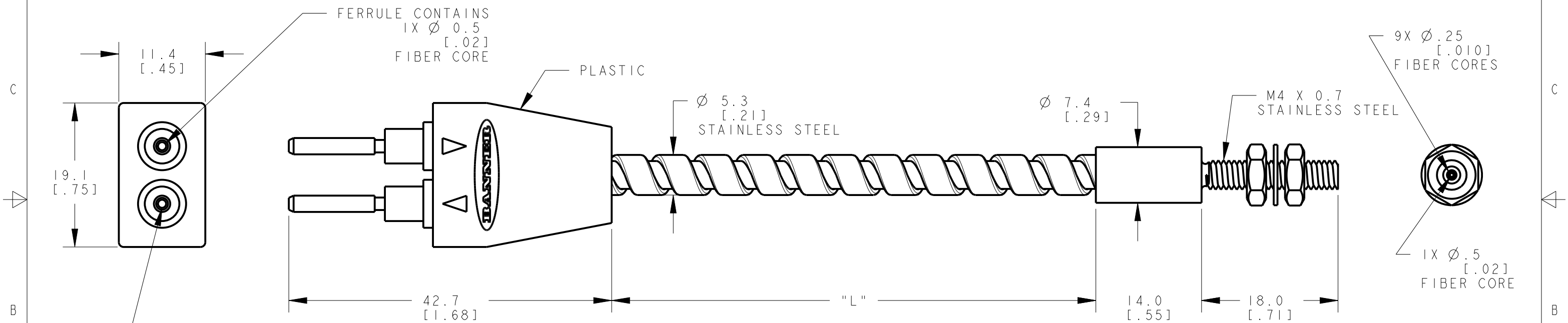

FERRULE CONTAINS
9X \varnothing 0.25
[.010]
FIBER CORES

- NOTES:
1. ALL DIMENSIONS ARE MILLIMETERS [INCHES] UNLESS OTHERWISE NOTED.
2. REFER TO "www.bannerengineering.com" FOR ADDITIONAL DATA AND SPECIFICATIONS.

This drawing is the property
of BANNER ENGINEERING CORP.
Any use or reproduction,
in any form, without prior
written permission of
Banner is prohibited.
© 2015 Banner Engineering Corp.



BANNER ENGINEERING CORP.
www.bannerengineering.com

TITLE

PBCT2 SERIES TERMINATED

SIZE
B

DRAWING NO. **188742**

REV. **A**

SCALE 2:1

SHEET 1 OF 1

CREO

